

# International Journal of Multidisciplinary Research Transactions

(A Peer Reviewed Journal)

www.ijmrt.in



## Vibration Monitoring and analysis using dSPACE Card

Shanmugavalli M <sup>1</sup>, Pranav Kumar S <sup>2</sup>, Suriya Prakaash D <sup>3</sup>, Kabilleshwaran R <sup>4</sup>, Sathish Kumar M <sup>5\*</sup>

<sup>1</sup> Professor, Department of Instrumentation and Control Engineering, Saranathan College of Engineering, Tamil Nadu India,

<sup>2,3,4,5</sup> student, Department of Instrumentation and Control Engineering, Saranathan College of Engineering, Tamil Nadu, India

\*Corresponding author

DoI: <https://doi.org/10.5281/zenodo.6624540>

---

### Abstract

Vibration monitoring in the industrialized and domestic applications is important and many complications can occur due to absence of improper vibration monitoring method. Vibration analysis provides relevant information about abnormal working condition of machine parts. Vibration measurement is prerequisite for vibration analysis which is used for condition monitoring of machinery. This paper presents implementation of a reliable and efficient vibration monitoring system using MATLAB & dSPACE card. In this project we are using the digital Storage Oscilloscope the data can be accessed via real time graphical representation. This project model will continuously measure and monitor the vibration in any device which is operated. In Digital Storage Oscilloscope the data can be viewed in graphical representation and display format is also viewed. This project can be implemented in various industrial sectors such as automotive industries, power plant and other industries that need the data to be saved and analyzed.

---

**Keywords:** Vibration, dSPACE, Continuous Monitoring, MATLAB, Simulink, Control Desk 7.2.

---

## 1. INTRODUCTION

Page | 14

Vibration monitoring is the process of using sensors to monitor small movements of various types of rotating machinery. Increasing vibration levels can be indicative of a developing failure, malfunction, or process restriction. Properly monitoring vibration of rotating equipment is a key component of a successful predictive maintenance program and can lead to a decrease in unscheduled outages, optimization of machine performance, and a reduction of repair and maintenance costs.

dSPACE stand for ‘Digital Signal Processing and Control Engineering’ flexible hardware systems are in widespread use in the automotive industry and are also employed in drives, aerospace and industrial automation, use dSPACE tools throughout the entire process or individual stages, you can rely on dSPACE to make a real impact on the efficiency of your development cycle. Using the dSPACE to measure and analysis the vibration. Using the MATLAB, Simulink and sensor to measure the process parameter as a vibration in the real time environment and analyze the output of the process parameters in the graphical representation via control Desk 7.2 software.

Vibration analysis is a measurement tool used to identify, predict, and prevent failures in machine tools [1]. It involves the analysis of machinery performance parameters to detect and identify problems before failure and extensive damage can occur. The vibration which occurs in most machines, vehicles, structures, buildings and dynamic systems is undesirable, not only because of the resulting unpleasant motions and the dynamic stresses which may lead to fatigue and failure of the structure or machine, but also because of the energy losses, reduction in performance and the noise produced. Since the vibration frequency and amplitude cannot be measured by sight or touch, a means must be employed to convert the vibration into a usable product that can be measured and analyzed [2].

Maintenance costs are a significant part of the total operating cost of all manufacturing plants. Condition monitoring is a key element of the maintenance program. Most comprehensive predictive maintenance programs use vibration as the primary parameter to monitor. However, the typical process of vibration monitoring relies too much on the human factor and has limitations. To overcome these shortcomings, a method is proposed in this paper [3].

Maintenance is required in regular interval of time. There are various types of maintenance techniques of a machine through which the fault can be detected. In break down maintenance, regular servicing of machine is not done until the machine breaks down. In preventive maintenance, machine requires regular maintenance after stipulated time period whether the machine runs or not. At that particular period, the work of machine has been stopped. It is costly method of maintenance because production has been stopped at that period. In

predictive maintenance, the performance & relative data of machinery have been collected. This helps for planning the maintenance of machinery in advance that results less maintenance cost. Due to smooth efficiency and productivity, the operating cost can be reduced. Predictive maintenance technique includes vibration monitoring system [4].

dSPACE based real time implementation of predictive current control scheme for grid connected two level voltage source converters, the cost function evaluates the error between reference and predicted grid currents and selects an optimal switching state based on the minimum error value [5].

Application of dSPACE microprocessor platform for the study of electric generators using renewable energy sources (RES), integration with MATLAB/Simulink RTI, which enables the rapid prototyping of control algorithms that are developed and simulated in Simulink [6].

The synchronous machine with permanent magnets is a very interesting solution for the generation of electrical energy in isolated and autonomous wind turbine applications, but the stability of the voltage remains a major problem in its use. that's why we're proposing in this paper the analysis of a control scheme for keeping the RMS voltage output constant, the system is supplying by a permanent magnet synchronous generator (PMSG) with variable speed and load A comparison is examined between experimental results using dSPACE board. The results are provided to verify the effectiveness of this approach and gives very high performance [7].

This paper presents a photovoltaic system with maximum power point tracking facility. An intelligent Sliding mode controller method is proposed in this paper to achieve the maximum power point tracking of PV modules. The system consists of a photovoltaic solar module connected to a DC-DC boost converter. The system is modeled using MATLAB/SIMULINK. The simulation results show that the proposed maximum power tracker tracks the maximum power accurately and successfully in all tested conditions [8].

In this paper to create a simulink program for vibration monitoring using the simulink library blocks, in this method using blocks are Sine input, multiplexer, Scope, Integrator, Gain, Out Simout, Bus Creator. Use in this blocks vibration monitoring and finally output view in the graphical representation using scope function.

In this method vibration monitoring output view in the real time using Digital Storage Oscilloscope (DSO), already created the vibration monitoring simulink program in the first method, that simulink program to be build and after building supporting files are added in the given root path or file location, and open the software as control desk 7.2 and created a file, import the builded vibration monitoring simulink file.

Additionally added simulink blocks as Master Input/output because to connect the DSO through the dSPACE card and also set the channel it is user defined.

dSPACE card have an analog and digital channels which channel to be given in simulink program (example: ADC channel 5 or DAC channel 7) in the channel to connect the Digital

Storage Oscilloscope (DSO) using the probes and adjust the x and y rays view the response in the real time.

## 2. BLOCK DIAGRAM

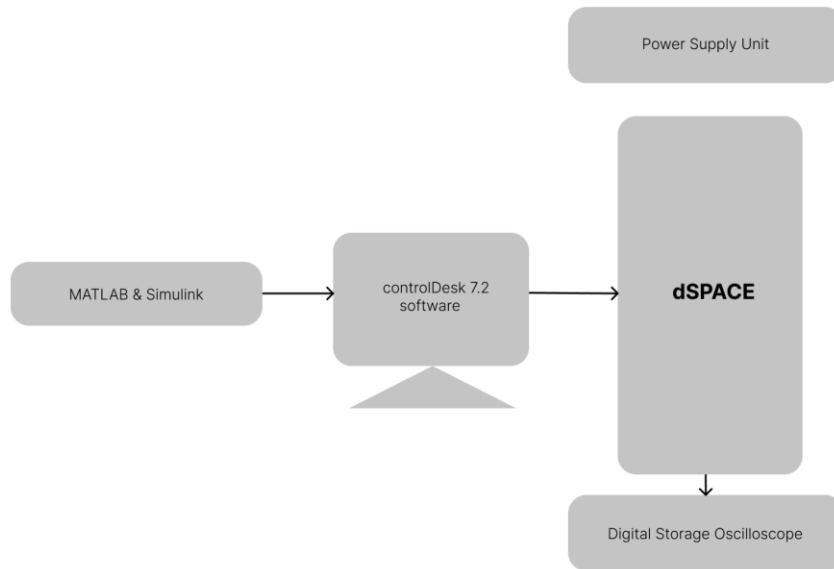

Figure 1 Block diagram of the system

## 3. HARDWARE DESCRIPTION

### 3.1 dSPACE:

The MATLAB Simulink tools depend on the dSPACE controller board in real-time implementation, which is a popular platform in academic research. dSPACE is a famous controller board, offering many advantages in terms of monitoring, controlling, and automating experiments and making the improvement of controllers more efficient.

The DS1104 controller board with the best response in terms of a high memory space and faster implementation process was considered in this study. The properties of the DS1104 controller board are explained in Fig. 3.1.1. This figure shows the general connection of the controller board with the personal computer and the converter (hardware). A photo of the DS1104 controller board is shown in Fig. 3.1.2, and the implementation flow of the dSPACE-based converter system is presented in Fig. 3.1.3.

Real-time interface (RTI) is the real-time adoption software for the dSPACE scheme that enhances the real-time C-code automation, faultlessly effects the dSPACE system and input/output hardware structure, and automatically creates, accumulates, connects, and performs the real-time C-code from the Simulink structure [29]. Moreover, RTI produces a variable file corresponding to signals and parameters, and ControlDesk will contact this file and update the parameters [29].

With RTI, one may simply run the function models on the DS1104 controller board. It configures each I/O graphically by pulling RTI blocks and decreases the implementation time to a minimum. The DS1104 enhances personal computers (PCs) with a strong improvement scheme for faster control implementation.

RTI produces Simulink blocks for the graphical structure of an analog-to-digital converter (ADC), a digital-to-analog converter (DAC), I/O lines, and PWM. Generally, the board may be installed in each PC with a free 5-V peripheral component interconnect (PCI) slot.

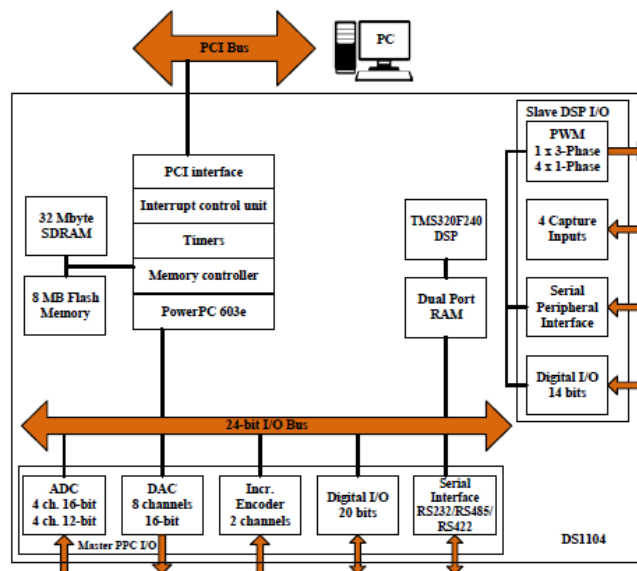

Fig 3.1.1 Block diagram of the DS1104 controller board.



Fig 3.1.2 Photo of the DS1104 controller board.

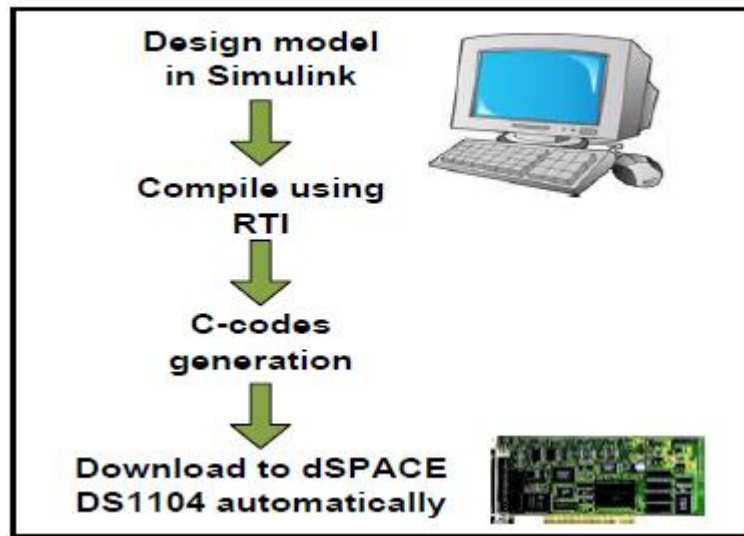

Fig 3.1.3 Flow of the implementation of the dSPACE-based converter system

There is a requirement for the signal conditioning circuits to be processed via the dSPACE controller board before feeding the signal. This requirement ensures that the voltage and current signals are specified in such a way that the levels match the ADC input range of the controller.

Depending on the level condition of the input, the signal undergoes the process of reduction, amplification or current-to-voltage conversion. The signal conditioning consists of AC voltage and current conditioning circuits, and DC voltage conditioning, as depicted in Fig. 3.1.4.

The computer must be prepared with the dSPACE-associated software and hardware, namely, the ControlDesk (dSPACE 2008) software and the DS1104 controller board. Some of the parameters must be measured or tested properly to be set as inputs to the controller. For this purpose, the measurement and dissipation circuits are required.

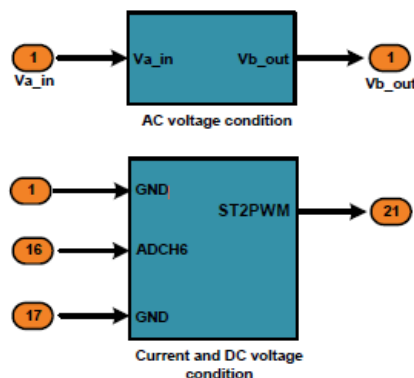

Fig 3.1.4 Signal conditioning.

The implementation of the MATLAB/Simulink converter control technique simulated in real time is proficient with the use of the dSPACE DS1104 RTI. In doing so, the required dSPACE input-output library blocks are involved in the control technique. Fig. 3.15 shows the dSPACE 1104 card.

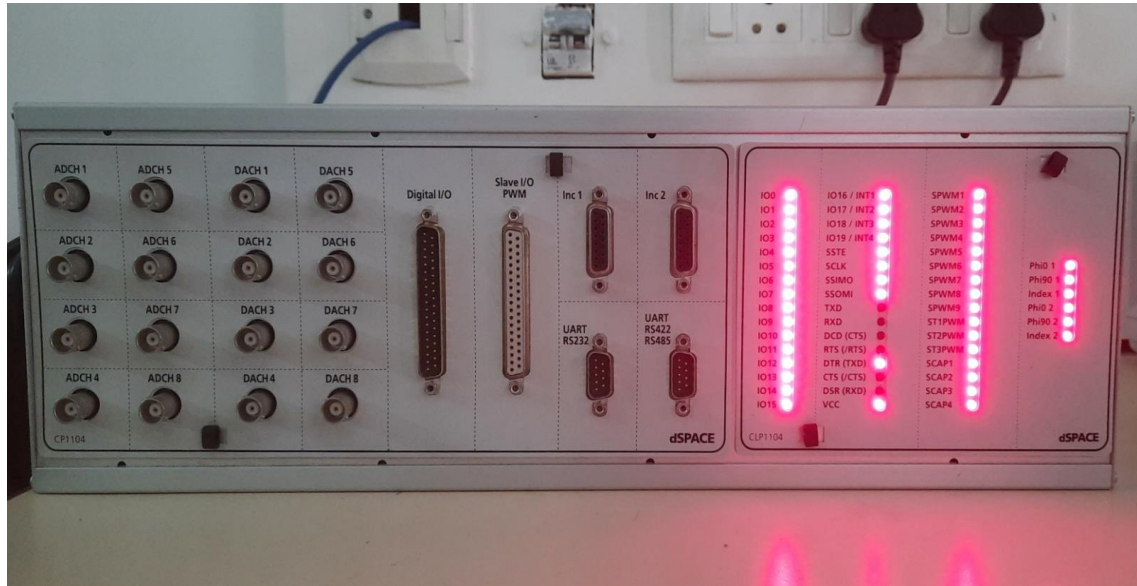

Fig 3.1.5 dSPACE 1104.

## 4. SOFTWARE DESCRIPTION

### 4.1 SIMULINK:

Simulink is a graphical extension to MATLAB for modeling and simulation of systems. One of the main advantages of Simulink is the ability to model a nonlinear system, which a transfer function is unable to do. Another advantage of Simulink is the ability to take on initial conditions. When a transfer function is built, the initial conditions are assumed to be zero.

In Simulink, systems are drawn on screen as block diagrams. Many elements of block diagrams are available, such as transfer functions, summing junctions, etc., as well as virtual input and output devices such as function generators and oscilloscopes.

Simulink is integrated with MATLAB and data can be easily transferred between the programs. In these tutorials, we will apply Simulink to the examples from the MATLAB tutorials to model the systems, build controllers, and simulate the systems.

Simulink is supported on Unix, Macintosh, and Windows environments; and is included in the student version of MATLAB for personal computers.



The idea behind these tutorials is that you can view them in one window while running Simulink in another window. System model files can be downloaded from the tutorials and opened in Simulink. You will modify and extend these systems while learning to use Simulink for system modeling, control, and simulation. Do not confuse the windows, icons, and menus in the tutorials for your actual Simulink windows.

Most images in these tutorials are not live - they simply display what you should see in your own Simulink windows. All Simulink operations should be done in your Simulink windows

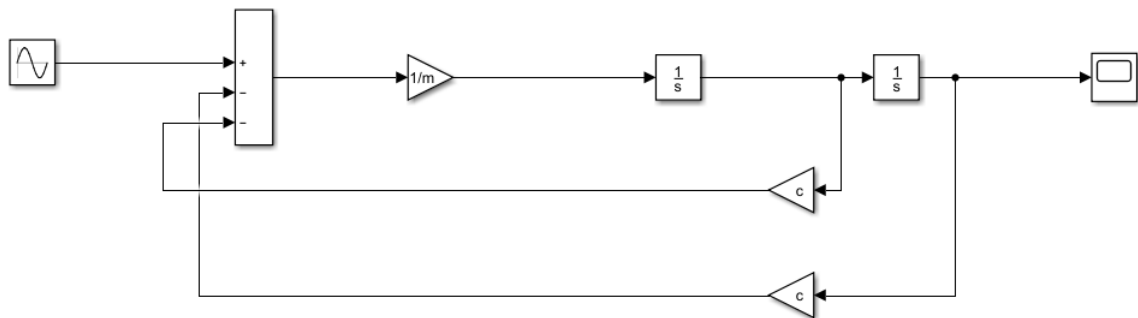

Fig 4.1.1 Simulink of Vibration Monitoring

Above the simulink diagram to monitor the vibration using the simulink library blocks such as input, multiplexer, Scope, Integrator, Gain, Out Simout, Bus Creator. To measure the vibration and scope to generate the output response. In RTI (real time interface) Master PPC using to get the real time output in Digital Storage Oscilloscope, to convert the digital output to analog output using DAC and to set the solver configurations and build the file.

## 4.2 CONTROL DESK:

Control Desk is the dSPACE experiment software for seamless ECU development. It performs all the necessary tasks and gives you a single working environment

- Integrated ECU calibration, measurement and diagnostics access (CCP, XCP, ODX)
- Synchronized data capture across ECUs, RCP and HIL platforms, and bus systems
- Powerful lay outing, instrumentation, measurement and post-processing (ASAM MDF)

Control Desk unites functionalities that often require several specialized tools.

It provides access to simulation platforms as well as to connected bus systems and can perform measurement, calibration and diagnostics on ECUs, e.g., via standardized ASAM interfaces.



Its flexible modular structure provides high scalability to meet the requirements of specific application cases. This gives you clear advantages in terms of handling, the amount of training needed, the required computing power, and costs.

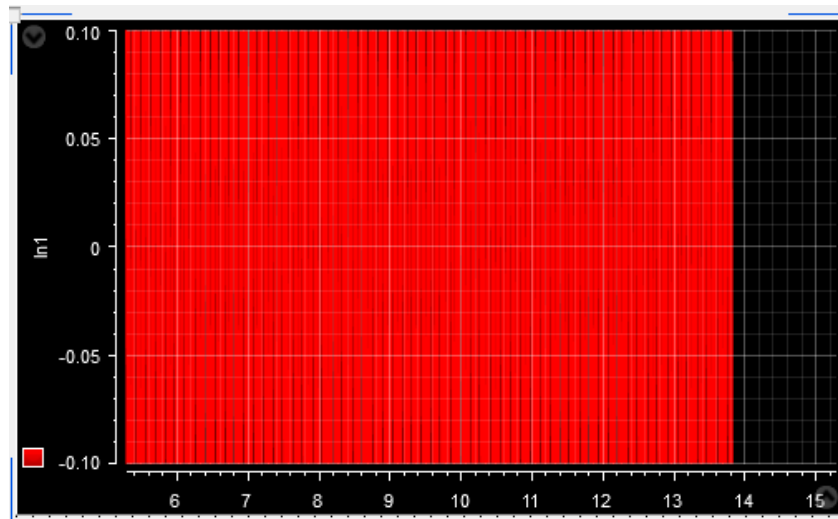

Fig 4.2.1 Control Desk 7.2 Vibration Monitoring

To create the control desk program to import the built simulink that file must be a “.sdf” extension and the variables tab have an input & outputs to select the Inputs/outputs and drag & drop to controldesk workspace and also is to be select the output plot in this case using the time plotter, save the file and go to the online to find the run to click it to measure the vibration in the time plotter above diagram as shown as Fig 4.2.1

### 5. EXPERIMENTAL SETUP/HARDWARE PROTOTYPE

The below figure depicts the hardware prototype that has been developed to realize the proposed methodology. The tests were conducted using the below experimental setup.

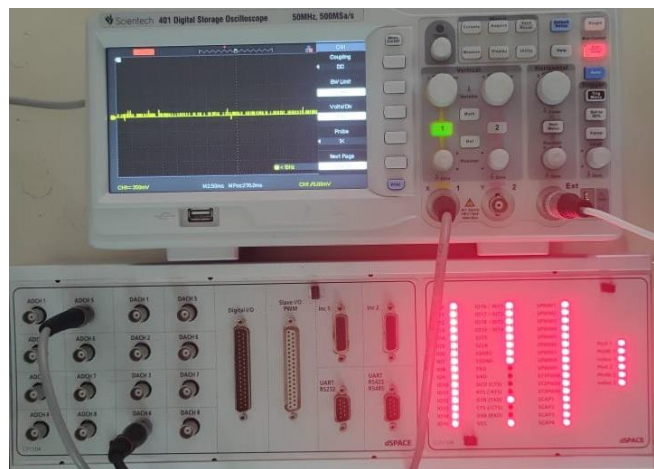

Fig 5.1 Experimental Setup

## 6. PROCESS DESCRIPTION

To create a simulink program for vibration monitoring using the simulink library blocks, in this method using blocks are Sine input, multiplexer, Scope, Integrator, Gain, Out Simout, Bus Creator. Use in this blocks vibration monitoring and finally output view in the graphical representation using scope function. In this method vibration monitoring output view in the real time using Digital Storage Oscilloscope (DSO), already created the vibration monitoring simulink program in the first method, that simulink program to be build and after building supporting files are added in the given root path or file location, and open the software as control desk 7.2 and created a file, import the builded vibration monitoring simulink file.

Additionally added simulink blocks as Master Input/output because to connect the DSO through the dSPACE card and also set the channel it is user defined. dSPACE card have an analog and digital channels which channel to be given in simulink program (example: ADC channel 5 or DAC channel 7) in the channel to connect the Digital Storage Oscilloscope (DSO) using the probes and adjust the x and y rays view the response in the real time.

Open the project vibration monitor.slx proj in the MATLAB simulink and import the builded file of vibration monitor controldesk 7.2 software is must be a sdf extension. Confirm that dSPACE 1104 is connected to your computer and also connect the DSO which channel to be given in simulink program (example: ADC channel 5 or DAC channel 7) in the channel to connect the Digital Storage Oscilloscope (DSO) using the probes. To go online and run the program either by clicking the Run button on the toolbar or by pressing Ctrl+R. channels and adjust the x and y rays in the DSO view the response in the real time.

## 7. RESULT

In vibration monitoring output response view in the scope and dSPACE controldesk7.2 software shown as Fig 7.1.1 and also view the output response in real time using dSPACE Card & Digital Storage Oscilloscope as shown in Fig 7.1.2.

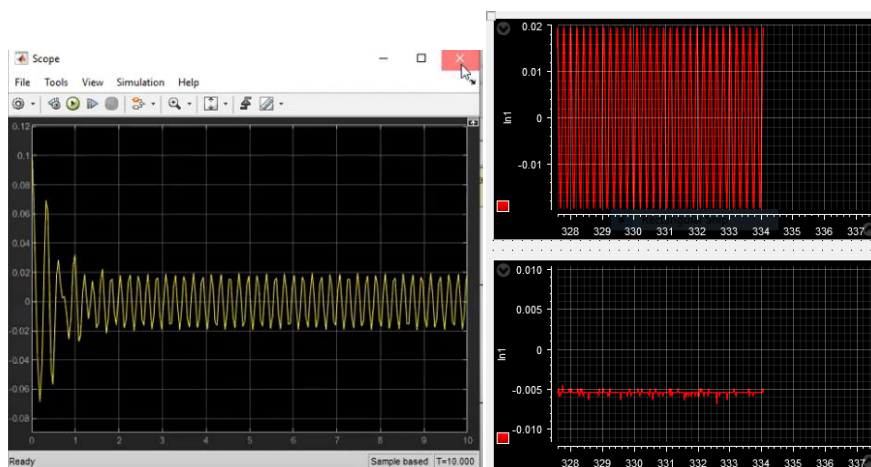

Fig 7.1.1 MATLAB scope response & controldesk 7.2 output



Fig 7.1.2 Realtime output in Digital Storage Oscilloscope (DSO)

## 8. CONCLUSION

As a conclusion, the Real Time Vibration Monitoring System has successfully been developed which shows an alternative to ease the monitoring process, in this system vibration monitoring by two methods. In first method to create a program in MATLAB simulink for vibration monitoring and output view in the scope and second method view the output response in real time using dSPACE Card & Digital Storage Oscilloscope (DSO), this system is very efficient and also validate the output response to compare the first method MATLAB scope function output and second method real time DSO response.

## REFERENCE

- [1] Senthilkumar M, Vikram M and Pradeep B, Vibration Monitoring for Defect Diagnosis on a Machine Tool: A Comprehensive Case Study. *International Journal of Acoustics and Vibration*, Vol. 20, No. 1, 2015.
- [2] UFaris Abdulhani Jabbar ALswede, Study of vibration for CNC machine at different feed. *International Journal of Advancements in Research & Technology*, Volume 3, Issue 11, 2014.
- [3] Khademi, F. Raji and M. Sadeghi, "IoT Enabled Vibration Monitoring Toward Smart Maintenance," 2019 3rd International Conference on Internet of Things and Applications (IoT), 2019, pp. 1-6.
- [4] Asan Gani and J.E. Salami, Department of Mechatronics, "Vibration Faults Simulation System (VFSS): A System for Teaching and Training on Fault Detection and

Diagnosis."Proceedings of student conference on research and development, SCORED, pp.15, 16, February 2002.

[5] C. Leffler et al., "Guidelines for dSPACE-based real-time implementation of predictive current control for gridconnected converters," 2017 IEEE Southern Power Electronics Conference (SPEC), 2017, pp. 1-8.

Page | 24

[6] R. Tansley et al., "The DSpace institutional digital repository system: current functionality," 2003 Joint Conference on Digital Libraries, 2003. Proceedings. 2003, pp. 87-97

[7] Z. Zarkov, "Application of dSPACE Platform in the Study of Electric Generators with RES," 2018 20th International Symposium on Electrical Apparatus and Technologies (SIELA), 2018, pp. 1-4.

[8] D. Arora, "Building Digital Library of Technology Focus Using Dspace," 2018 5th International Symposium on Emerging Trends and Technologies in Libraries and Information Services (ETTLIS), 2018, pp. 83-86.