

# International Journal of Multidisciplinary Research Transactions

(A Peer Reviewed Journal)

www.ijmrt.in



## Smart Industry Pollution Monitor and Control using IoT and LabVIEW

Aravind P<sup>1</sup>, Kaviyarasan K<sup>2</sup>, Mohamed Thasneem A<sup>3\*</sup>, Mohamed Javeed  
Ali S<sup>4</sup>, Kumaraguru K<sup>5</sup>

<sup>1</sup>Assistant Professor, Instrumentation and Control Engineering, Saranathan College of Engineering,  
Trichy, India

<sup>2,3,4,5</sup>Student, Instrumentation and Control Engineering, Saranathan College of Engineering, Trichy,  
India

\*Corresponding Author

DoI: <https://doi.org/10.5281/zenodo.6639115>

---

### Abstract

The majority applications of pollution monitoring systems are in industries. The control of the parameters which causes pollution and deteriorates the industrial and natural environment pattern is a great challenge and has received interest from industries especially in Petrochemical industries, Paper making industries, Water treatment industries and Sugar manufacturing industries. The main objective of our project is to design an efficient and robust system to monitor the parameters causing pollution and to minimize the effect of these parameters without affecting the plant or natural environment. The proposed methodology is to model a system to read and monitor pollution parameters and to inform pollution control authorities when any of these factors goes higher than industry standards. A mechanism using IoT and LabVIEW is introduced in this proposed methodology, which will automatically monitor when there is a disturbance affecting the system. The system is

---

implemented using LabVIEW software. The system investigates level of pH in industry effluents, level of CO gas released during industry process and temperature of the machinery.

With the design of IoT, the signals can be effectively transferred and the actions in these cases can still be made accurate and effective.

**Keywords:** IoT, LabVIEW, Pollution, Smart Industry.

---

## 1. Introduction

Nowadays, water quality monitoring in real time faces challenges because of global warming limited water resources, growing population etc. The Pollution's are growing very widely. Even though, Industrialization increases the air pollution by releasing the unwanted gases in environment mostly in industrial areas. So there must be a system to monitoring and controlling the industrial pollution. The terms monitoring and controlling are mostly confused as well as used similarly. The process of industrial quality control is the evaluation of industrial quality with respect to standard quality set by pollution controlling board. Especially the factors which may affect the human health and the health of the natural system itself. From this paper we design to how reduce a pollution in Environment caused by a Industry and also monitoring the physical parameters from anywhere by IoT and also monitoring at same place by seeing LabVIEW software.

They have establish a satellite terrestrial framework to detect and locate industrial pollution areas by integrating satellite with IoT, and the massive amount of sensor data can be delivered to the satellite via a ground base station (BS). The local attribute detection inspired by recent advances in graph signal processing provides a promising way for solving

---

this problem. A sub-graph can be formed by grouping the vertices with identical attributes, and these vertices can be easily separated from other vertices based on local attribute detection. This methods based on local attribute detection are proposed to detect and locate pollution areas.

First, stable wavelet statistic (SWS) is proposed by modeling the classical wavelet basis as a graph-based wavelet basis. To improve the generalization ability of SWS, a new cluster center discovery method is proposed to minimize the distance between any vertex and the reminding vertices of the same cluster. Second, the smooth scan statistic (SSS) is proposed by introducing a new constraint to simplify the problem formulation of the likelihood ratio tested [1].

In This existing paper investigated how the fusion of data taken by sensor arrays can improve the calibration process. In particular, calibration with sensor arrays, multi-sensor data fusion calibration with weighted averages, and multi-sensor data fusion calibration with machine learning models are compared. Calibration is evaluated by combining data from various sensors with linear and nonlinear regression models [2].

They have proposed developed designs for IoT enabled Power Monitoring. First is the non-invasive power monitor with voltage connection. The second design introduces a novel split architecture with centralized voltage measurement, which removes the need for local voltage measurements. We have proposed the third and final version of the IoT enabled power monitor to fulfill the need for three-phase power monitoring. Unlike first and second designs, this design can be used with non-invasive as well as invasive current sensors. The proposed architecture also supports essential features such as secure data transfer. Developed devices transmit real-time data to the cloud server, which makes the data ubiquitously available anywhere and anytime. For analyzing the performance of the proposed architecture, the developed devices are deployed in real industrial scenarios. As an

example use case, electrical anomaly detection framework using the data collected is also explained and corresponding results are discussed [3].

## 2. HARDWARE DISCRIPTION

### 2.1. pH SENSOR:

A pH Meter is a device used for potentiometrically measuring the pH, which is either the concentration or the activity of hydrogen ions, of an aqueous solution. It usually has a glass electrode plus a calomel reference electrode, or a combination electrode. pH meters are usually used to measure the pH of liquids, though special probes are sometimes used to measure the pH of semi-solid substances. The pH sensor working in 5v DC supply and the output of the pH sensor is Analog.



**Figure.1 pH Sensor**

### 2.2. Gas sensor:

This sensor has a high sensitivity and fast response time. The sensor's output is an analog resistance. The drive circuit is very simple all you need to do is power the heater coil with 5V adds a load resistance and connects the output to an ADC.

MQ-2 Gas Sensor is designed with sensitive material of  $\text{SnO}_2$ , which with lower conductivity in clean air. When the target combustible gas exists, the sensor's conductivity is higher. Signal conditioning circuit is used to convert the change of conductivity to correspond output signal with the input gas concentration. MQ-2 gas sensor has high sensitivity to LPG, Propane and Hydrogen, also could be used to

Methane and other combustible steam, it is with low cost and suitable for different application.

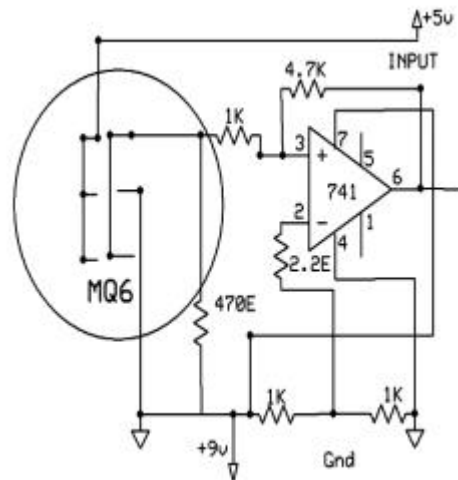

**Figure.2. Gas Sensor**

### 2.3. Temperature Sensor:

LM35 is a temperature sensor that outputs an analog signal which is proportional to the instantaneous temperature. The output voltage can easily be interpreted to obtain a temperature reading in Celsius. The advantage of LM35 over thermistor is it does not require any external calibration. The coating also protects it from self-heating. Low cost (approximately \$0.95) and greater accuracy make it popular among hobbyists, DIY circuit makers, and students. Many low-end products take advantage of low cost, and greater accuracy and used LM35 in their products. The working principle of LM35 temperature sensor we have to understand the linear scale factor. In the features of LM35, it is given to be +10 millivolts per degree centigrade. It means that with an increase in output of 10 millivolts by the output pin the temperature value increases by one. For example, if the sensor is outputting 100 millivolts at the output pin the temperature in centigrade will be 10-degree

centigrade. The same goes for the negative temperature reading. If the sensor is outputting -100 mills volt the temperature will be -10 degrees Celsius.

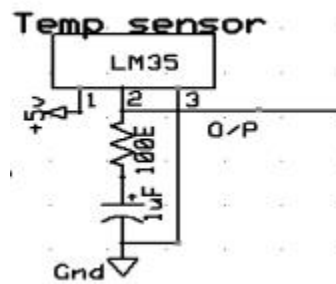

Figure.3 Temperature Sensor.

#### 2.4: PIC Micro-controller:

PIC is a family of Harvard architecture micro-controllers made by Microchip Technology, derived from the PIC1640. Originally developed by General Instrument's Microelectronics Division. The name PIC initially referred to "**Programmable Interface Controller**".

Micro-controller is a general purpose device, which integrates a number of the components of a microprocessor system on to single chip.

It has inbuilt CPU, memory and peripherals to make it as a mini computer.

A micro-controller combines on to the same microchip:

- CPU core
- Memory (both ROM and RAM)

**Pin Description:** PIC16F877A consists of 40 pins enclosed in 5 ports. Each port holds 8pins which are bidirectional input/output pins.

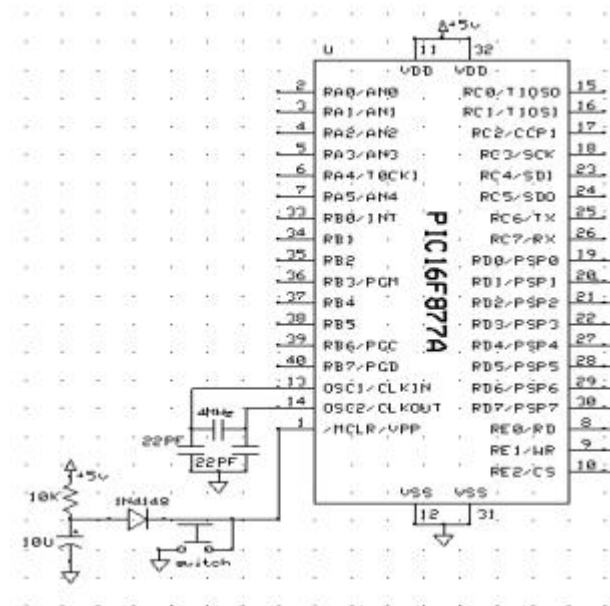
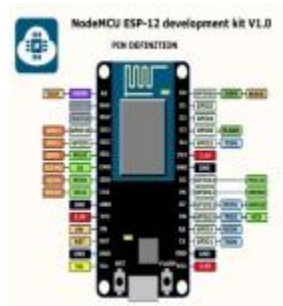

**Figure.4 PIC Micro-controller.**

## 2.5. IoT (Internet of Things):

The Node MCU (Node Micro controller Unit) is an open-source software and hardware development environment built around an inexpensive System-on-a-Chip (SoC) called the ESP8266. The ESP8266, designed and manufactured by Express if Systems, contains the crucial elements of a computer: CPU, RAM, networking (WiFi), and even a modern operating system and SDK. That makes it an excellent choice for Internet of Things (IoT) projects of all kinds. However, as a chip, the ESP8266 is also hard to access and use. You must solder wires, with the appropriate analog voltage, to its pins for the simplest tasks such as powering it on or sending a keystroke to the “computer” on the chip. You also have to program it in low-level machine instructions that can be interpreted by the chip hardware. This level of integration is not a problem using the ESP8266 as an embedded controller chip in mass-produced electronics. It is a huge burden for hobbyists, hackers, or students who want to experiment with it in their own IoT projects. The prototyping hardware typically used is a circuit board functioning as a

dual in-line package (DIP) which integrates a USB controller with a smaller surface-mounted board containing the MCU and antenna. The choice of the DIP format allows for easy prototyping on breadboards. The design was initially based on the ESP-12 module of the ESP8266, which is a Wi-Fi SoC integrated with a TensilicaXtensa LX106 core, widely used in IoT applications.



**Figure.5. Internet of Things**

### **3. Software Description**

#### **3.1. LabVIEW Software**

LabVIEW (Laboratory Virtual Instrument Engineering Workbench) is a graphical programming environment which has become prevalent throughout research labs, academia, and industry.

It is a powerful and versatile analysis and instrumentation software system for measurement and automation. Its graphical programming language called G programming is performed using a graphical block diagram that compiles into machine code and eliminates a lot of the syntactical details.

LabVIEW offers more flexibility than standard laboratory instruments because it is software-based. Using LabVIEW, the user can originate exactly the type of virtual instrument needed and programmers can easily view and modify data or control inputs.



The popularity of the National Instruments LabVIEW graphical data-flow software for beginners and experienced programmers in so many different engineering applications and industries can be attributed to the software’s intuitive graphical programming language used for automating measurement and control systems.

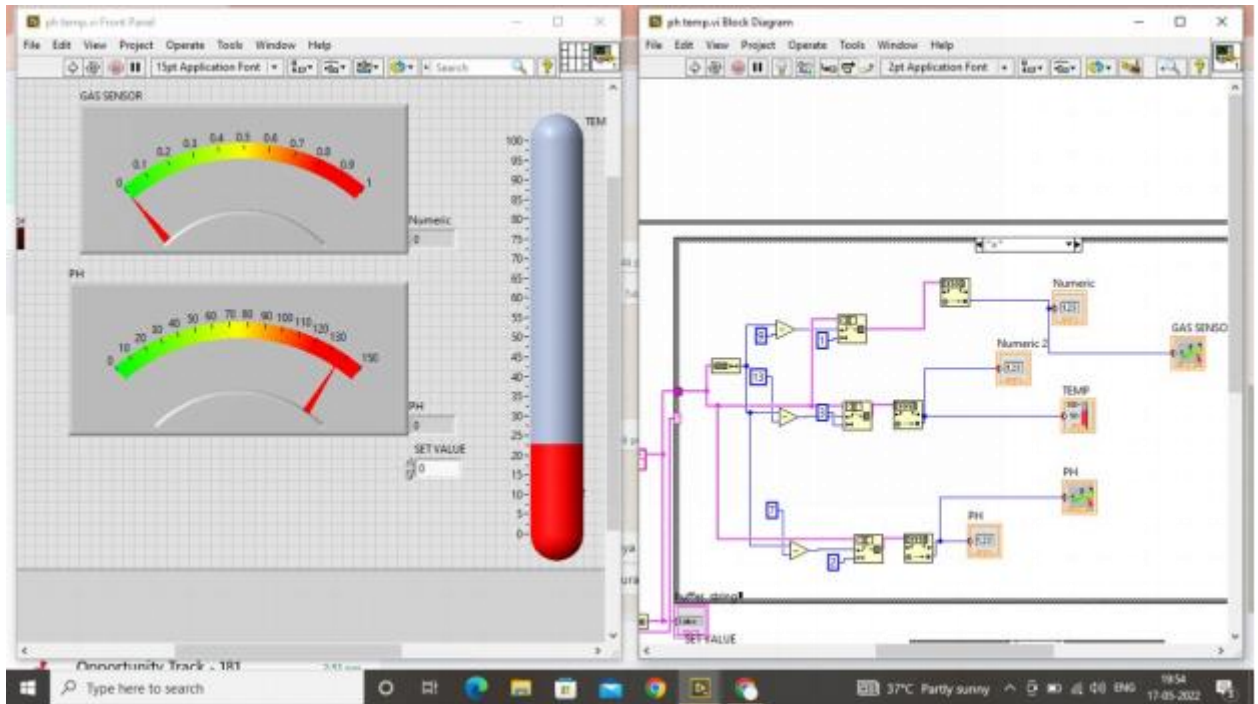
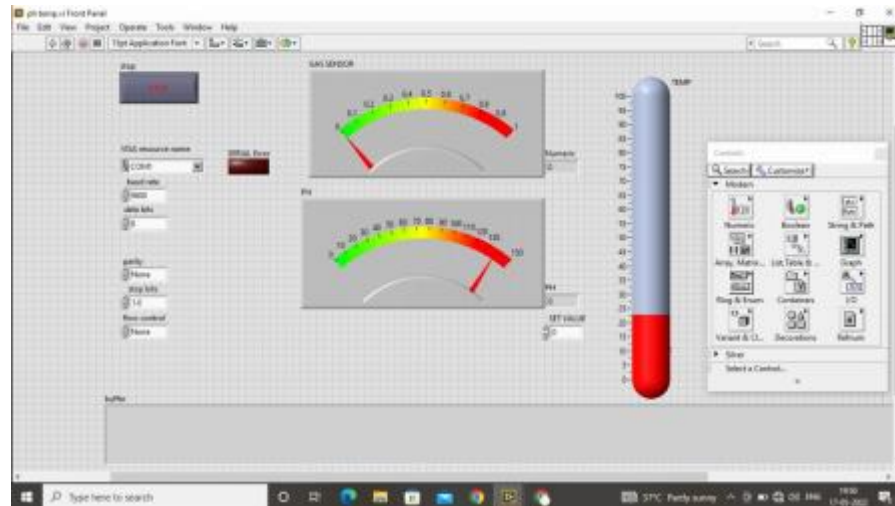

Figure.6. Front and Block Diagram Window of LabVIEW Software.

#### 4. Result



**Figure.7. Real time Output in IoT****Figure.8. Real time Output in LabVIEW**

In this project we developed smart industry monitoring system, from Figure it shows Real time monitoring the physical parameters like Temperature, Gas and pH values using IoT module and it can also be accessed by any were at any time. From Figure, An output of LabVIEW Software and it is used for monitoring the System using Personal Computers.

## 5. Conclusion

This project is made with pre planning, thus it provides flexibility in operation. Thus a cost effective and user-friendly system has been developed to monitor the pollutants in the industry effectively. There by limiting the pollution in the environment. The data set which we have utilized in this model is for a short period that restricts the prototype's ability. So, the utilization of data which have longer periods with unimportant data gaps is suggested for farther improvise. We can initiate more effective elements such as precipitation, maximum

and minimum temperature, PH sensor, and gas sensor, for future work to increment the exactness of the system.

## REFERENCE

- [1]. X. Liu, M. Jia, X. Zhang, and W. Lu, "A novel multichannel internet of things based on dynamic spectrum sharing in 5g communication," *IEEE Internet of Things Journal*, vol. 6, no. 4, pp. 5962–5970, 2018.
- [2]. A. Sandryhaila and J. M. Moura, "Discrete signal processing on graphs," *IEEE Transactions on Signal Processing*, vol. 61, no. 7, pp. 1644–1656, 2013.
- [3]. D. Shuman, S. Narang, P. Frossard, A. Ortega, and P. Vandergheynst, "The emerging field of signal processing on graphs: Extending highdimensional data analysis to networks and other irregular domains," *IEEE Signal Processing Magazine*, vol. 3, no. 30, pp. 83–98, 2013.
- [4]. A. Ortega, P. Frossard, J. Kovacevic, J. M. Moura, and P. Vandergheynst, "Graph signal processing: Overview, challenges, and applications," *Proceedings of the IEEE*, vol. 106, no. 5, pp. 808–828, 2018.
- [5]. J. M. Samet, F. E. Speizer, Y. Bishop, J. D. Spengler, and B. G. Ferris Jr, "The relationship between air pollution and emergency room visits in an industrial community," *Journal of the Air Pollution Control Association*, vol. 31, no. 3, pp. 236–240, 1981.
- [6]. K. Gu, J. Qiao, and W. Lin, "Recurrent air quality predictor based on meteorology- and pollution-related factors," *IEEE Transactions on Industrial Informatics*, vol. 14, no. 9, pp. 3946–3955, Sep. 2018.